

Tax Rate Area
51-01

PORTION E 1/2, NW 1/4 SEC.29, T.8N., R.23E., M.D.B.M.
MILL CREEK RANCH SUBDIVISION (WESTERN DRIVE)

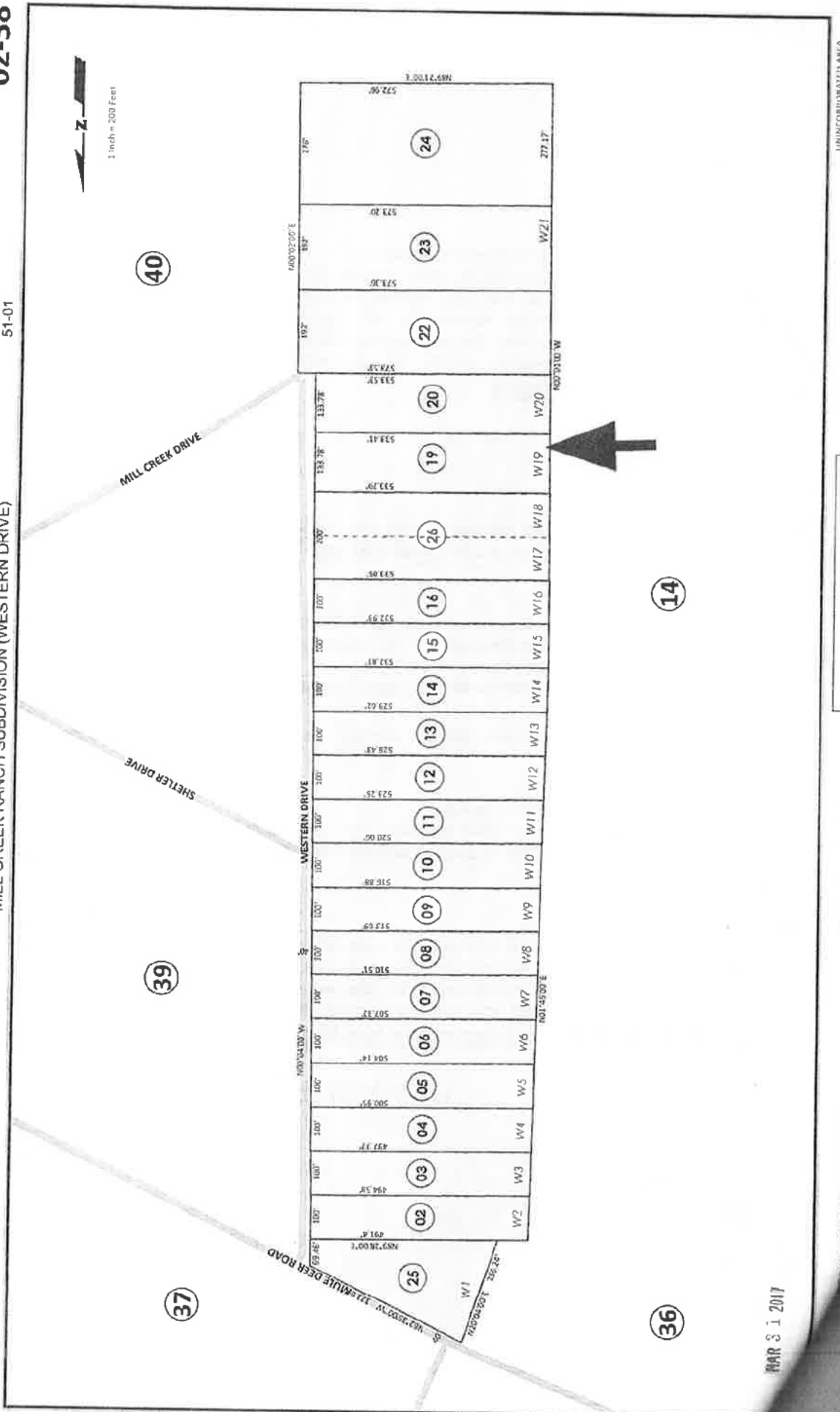

Note: This map is prepared for the use of the Mono County Assessor. It is not a survey of the land, but is for information only. It does not necessarily represent a warranty of accuracy or liability on the part of the assessor or the county of the date of preparation.

This is not a survey of the land, but is for information only. It does not necessarily represent a warranty of accuracy or liability on the part of the assessor or the county of the date of preparation.

2015005044 (02-380-026)
MILL CREEK RANCH SUBDIVISION

Revised By: R. O'Shea/Blair	Created: 3/22/2013	Revised: 3/22/2013
Mono County - Geographical Information		

MAR 31 2017

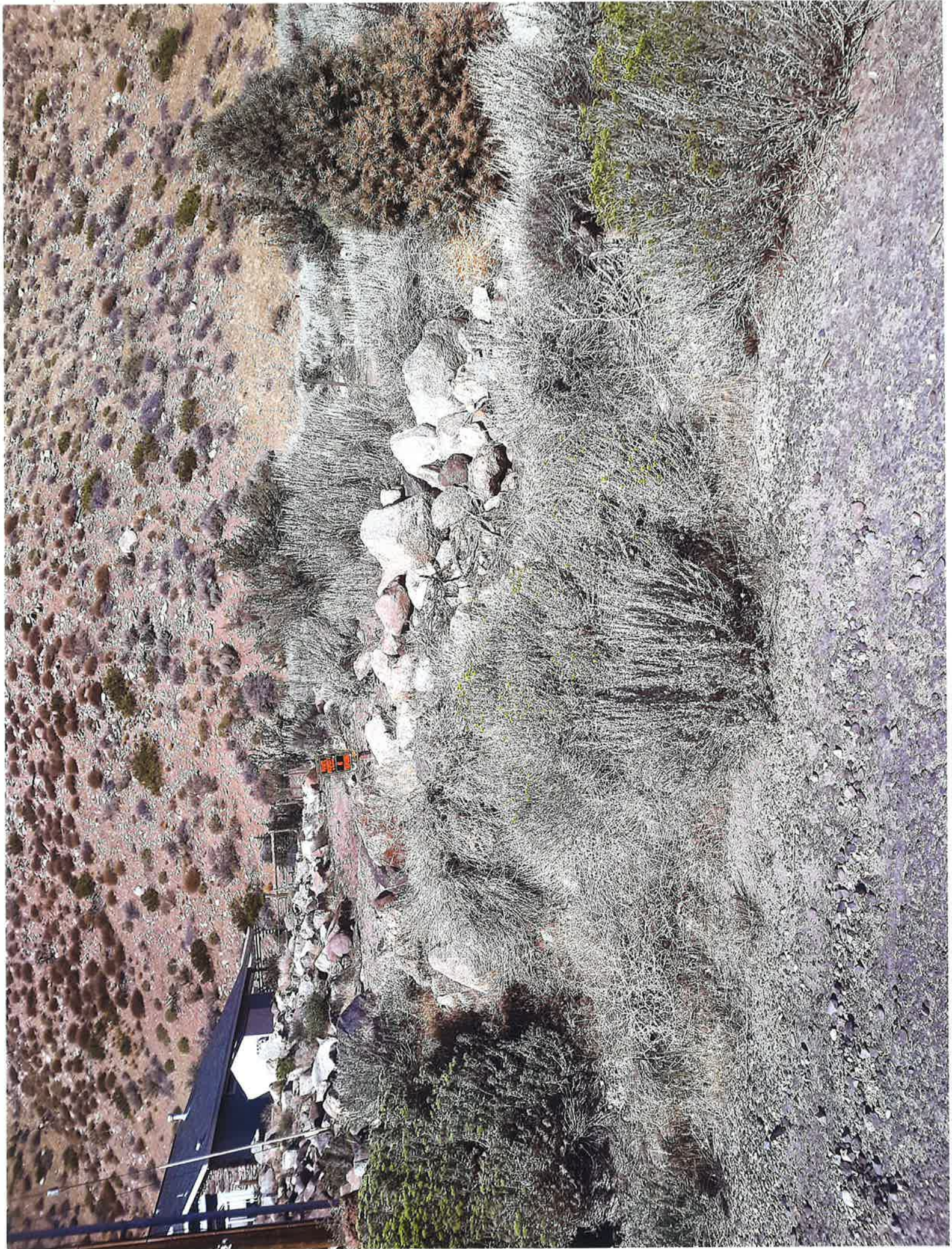



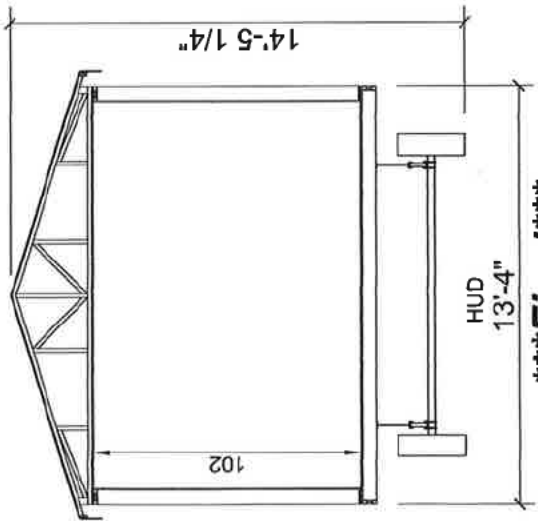

HUD
13'-4"
*****Final***
for
Production!!**

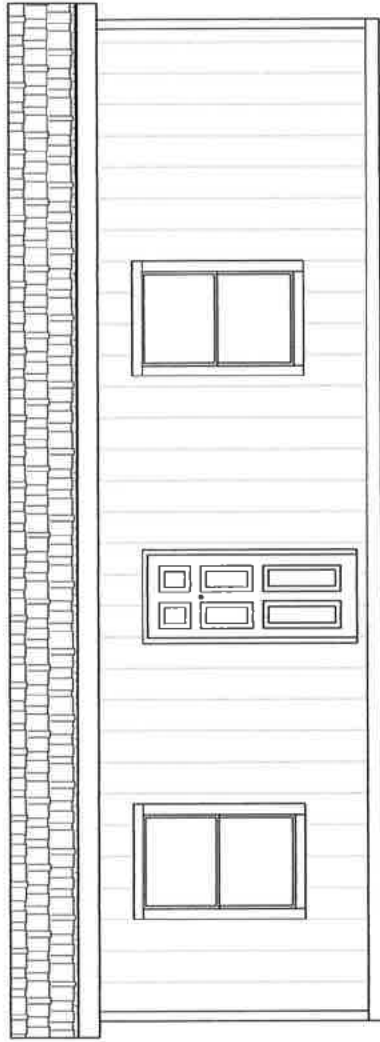
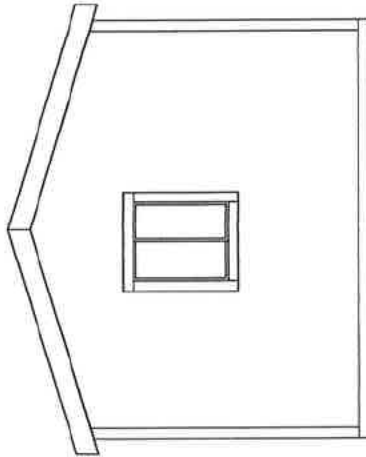

FRONT SIDE ELEVATION

HITCH END

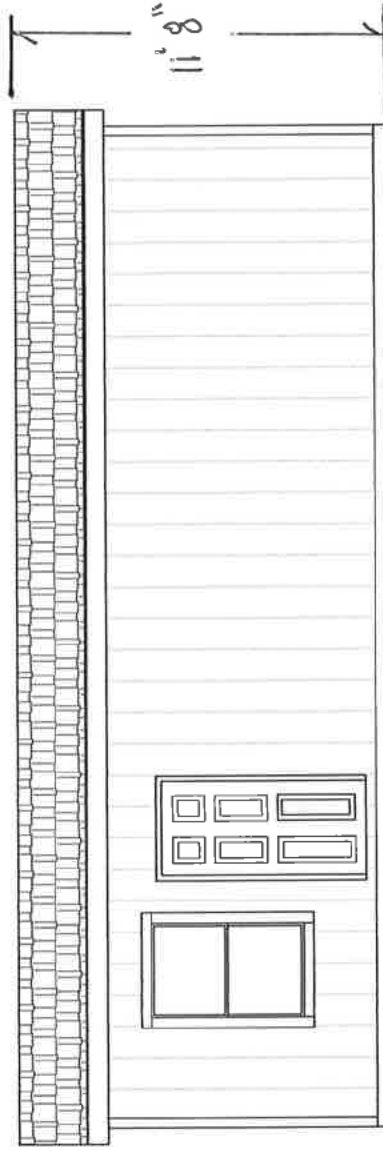

REAR SIDE ELEVATION

HITCH END

<p>CHAMPION MANUFACTURED BEAUTIFULLY™ 788 W. 180 BEAVER ROAD, SUITE 1000 TRACY, CA 95376 PHONE: 937.471.8200</p>	<p>PROJECT: 17-TA1321K 13'-4" x 32' 1 BD 1 BTH</p>	<p>TITLE: ELEVATION</p>	<p>SHEET: EV-101</p>
	<p>MODIFICATIONS:</p>	<p>FILENAME: TA-1321K 6-15 VUE</p>	<p>PROPRIETARY AND CONFIDENTIAL THESE DRAWINGS AND SPECIFICATIONS ARE LEGAL INSTRUMENTS OF SERVICE. ANY REUSE, REPRODUCTION OR ALTERATION WITHOUT CONSULTATION IS STRICTLY PROHIBITED.</p>
	<p>DRAWN BY: [REDACTED] DATE: 03-23-18 SCALE: SIZE = 1/2"</p>		