

Mono County Community Development Department

PO Box 347
Mammoth Lakes CA, 93546
760.924.1800, fax 924.1801
commdev@mono.ca.gov

Planning Division

PO Box 8
Bridgeport, CA 93517
(760) 932-5420, fax 932-5431
www.monocounty.ca.gov

SPECIFIC PLAN CHECKLIST

APPLICATION PACKET SHALL INCLUDE:

- Completed Application form.
- Completed Project Information form.
- Completed Environmental Processing & Review agreement
- Deposit for project processing: See Development Fee Schedule for Specific Plan. Project Applicants are responsible for costs incurred above deposit amount.
- Environmental Review (CEQA): See Development Fee Schedule for Negative Declaration and Environmental Impact Report. Applicants must prepay the contract estimate for environmental review, plus 20% deposit for staff time. Applicants are responsible for cost incurred above the prepaid amount.
- Specific Plan information: Each of the following items is required by state law to be included in the text and/or diagrams of the specific plan. The information you provide in this application will be used to prepare a specific plan and supporting environmental documents. Please provide as much information as possible regarding the following items. Failure to do so may delay application processing.
 - Distribution, location and extent of uses of land, including open space, within the area covered by the plan.
 - Proposed distribution, location, and extent and intensity of major components of public and private transportation, sewage, water, drainage, solid waste disposal, energy and other essential facilities proposed to be located within the area covered by the plan and needed to support the land uses described in the plan.
 - Standards and criteria by which development will proceed, and standards for the conservation, development, and utilization of natural resources, where applicable.
 - Program of implementation measures including regulations, programs, public works projects, and financing measures necessary to carry out the items above and complete the project.
 - Statement of the relationship of the Specific Plan to the General Plan.

CERTIFICATION: I hereby certify that I have furnished in the attached exhibits the data and information required for this initial evaluation to the best of my ability, and that the information presented is true and correct to the best of my knowledge and belief. I understand that this information, together with additional information that I may need to provide, will be used by Mono County to prepare a Specific Plan in compliance with state law.



Signature

2 - 26 - 2021
Date

**Mono County
Community Development Department**

PO Box 347
Mammoth Lakes, CA 93546
(760) 924-1800, fax 924-1801
commdev@mono.ca.gov

Planning Division

PO Box 8
Bridgeport, CA 93517
(760) 932-5420, fax 932-5431
www.monocounty.ca.gov

PROJECT INFORMATION

(To be completed by applicant or representative)

NOTE: Please answer all questions as accurately and completely as possible to avoid potential delays in processing. Attach additional sheets if necessary.

I. TYPE OF PROJECT (check any permit(s) requested):

- Director Review Use Permit Lot Line Adjustment Land Division (4 or fewer)
 Subdivision Specific Plan Variance General Plan Amendment
 Other _____

APPLICANT Tim and Paula Richards, Sierra del Oro Trading Co, LLC

PROJECT TITLE Rock Creek Ranch

LOT SIZE (sq. ft./acre) 54.67 acres ASSESSOR'S PARCEL # 26-330-02

PROJECT LOCATION Rock Creek Road, east of Paradise Lodge

Has your project been described in detail in the project application? Yes No

Please Specify:

Number of Units N/A Building Height/# of floors _____
Number of Buildings _____ Density (units/acre) _____

Total lot coverage/impervious surface (sq. ft. & %) 64,778/2.7
a. Buildings (first-floor lot coverage /sq. ft. & %) 14,460/0.6
b. Paved parking & access (sq. ft. & %) 46,778/1.0

Landscaping/screening and fencing: N/A
a. Landscaping (sq. ft. & %) _____
b. Undisturbed (sq. ft. & %) 2,316,521/97

Total parking spaces provided:
a. Uncovered _____
b. Covered _____
c. Guest/Handicapped _____

II. SITE PLAN

Are all existing and proposed improvements shown on the Plot Plan (see attached Plot Plan Requirements)? Yes No

III. ENVIRONMENTAL SETTING

Use one copy of the Tentative Map or Plot Plan as needed to show any necessary information. Attach photographs of the site, if available.

More on back...

1. VICINITY MAP:

Attach a copy of assessor's parcel pages or a vicinity map showing the subject property in relation to nearby streets and lots or other significant features.

2. EXISTING DEVELOPMENT:

Vacant If the site is developed, describe all existing uses/improvements such as structures, roads, etc. Does the Plot Plan show these uses? Yes No

3. ACCESS/CIRCULATION:

Name of Street Frontage(s) Lower Rock Creek Road

Paved Dirt No existing access

Are there any private roads, drives or road easements on/through the property?

Yes No

Has an encroachment permit been submitted to Public Works or Caltrans? Yes No

Does the property have any existing driveways or access points? Yes No

Are any new access points proposed? Yes No

Does the Plot Plan show the driveways or access points? Yes No

Describe the number and type of vehicles associated with the project N/A

4. ADJACENT LAND USES:

A. Describe the existing land use(s) on adjacent properties. Also note any major man-made or natural features (i.e., highways, stream channels, number and type of structures, etc.).

	<u>LAND USE</u>		<u>LAND USE</u>
North	<u>RM/BLM</u>	South	<u>OP</u>
East	<u>RM/BLM</u>	West	<u>RU</u>

B. Will the proposed project result in substantial changes in pattern, scale or character of use in the general area? Yes No If YES, how does the project propose to lessen potential adverse impacts to surrounding uses? _____

5. SITE TOPOGRAPHY:

Is the site on filled land? Yes No Describe the site's topography (i.e., landforms, slopes, etc.) The site slopes from the northeast to the southwest at an average

slope of approximately 15%

6. DRAINAGES:

A. Describe existing drainage ways or wetlands on or near the project site (i.e., rivers, creeks and drainage ditches 12" or deeper and/or within 30' of the property) _____

There is a drainage course in the NW corner of the site. No wetlands are present on site.

B. Are there any drainage easements on the parcel? Yes No

C. Will the project require altering any streams or drainage channels? Yes No If YES, contact the Department of Fish and Game for a stream alteration permit. IF YES TO ANY OF THE ABOVE, show location on plot plan and note any alteration or work to be done within 30 feet of the stream or drainage.

7. VEGETATION:

A. Describe the site's vegetation and the percentage of the site it covers (map major areas of vegetation on the Plot Plan) The entire site is covered in scattered sagebrush.

B. How many trees will need to be removed? 0

- C. Are there any unique, rare or endangered plant species on site? Yes No
- D. Has the site been used for the production of agricultural crops/trees or grazing/pasture land in the past or at the present time? Yes No
- E. Is landscaping/planting of new vegetation proposed? Yes No

8. WILDLIFE:

- A. Will the project impact existing fish and wildlife? Yes No
Describe existing fish and wildlife on site and note any proposed measures (if any) to avoid or mitigate impacts to fish and wildlife _____
There is no fish/wildlife that live on the site.
- B. Are there any unique, rare or endangered animal species on site? Yes No

9. CULTURAL RESOURCES:

- A. Are there any cemeteries, structures or other items of historical or archaeological interest on the property? Yes No Specify _____

10. SITE GRADING:

- A. Will more than 10,000 square feet of site area be cleared and/or graded? Yes No If YES, how much? 159,000
- B. Will the project require any cuts greater than 4' or fills greater than 3'? Yes No
- C. Will the project require more than 200 cubic yards of cut or fill? Yes No If YES, how much? 7,200 If YES to A, B or C, contact the Department of Public Works for a grading permit.
- D. Will site grading of 10% or more occur on slopes? Yes No
- E. Note any measures to be taken to reduce dust, prevent soil erosion, or the discharge of earthen material off site or into surface waters _____

Water trucks will be on-site to reduce dust. Erosion control will be in place when grading begins.

11. AIR QUALITY:

- A. Will the project have wood-burning devices? Yes No If YES, how many? _____
- B. What fuel sources will the proposed project use? Wood Electric Propane/Gas
- C. Will the proposal cause dust, ash, smoke, fumes or odors in the vicinity? Yes No

12. VISUAL/AESTHETICS:

- A. How does the proposed project blend with the existing surrounding land uses?
The project will conform to zoning and specific plan requirements.
- B. How does the proposed project affect views from existing residential/commercial developments, public lands or roads? Will not affect views
Please attached for more details _____
- C. If outdoor lighting is proposed, describe the number, type and location N/A

13. NATURAL HAZARDS:

- A. Is the site known to be subject to geologic hazards such as earthquakes, landslides, mudslides, ground failure, flooding, avalanche or similar hazards? Yes No (Circle applicable hazard[s]).
- B. Will any hazardous waste materials such as toxic substances, flammables or explosives be used or generated? Yes No
- C. Does the project require the disposal or release of hazardous substances? Yes No
- D. Will the project generate significant amounts of solid waste or litter? Yes No

E. Will there be a substantial change in existing noise or vibration levels? Yes No

If YES to any of the above, please describe _____
More on back...

14. OTHER PERMITS REQUIRED:

List any other related permits and other public approvals required for this project, including those required by county, regional, state and federal agencies:

- Encroachment Permits from *Public Works or Caltrans*.
- Stream Alteration Permit from *Department of Fish and Game*
- 404 Wetland Permit from *Army Corps of Engineers*
- Grading Permit from *Public Works*
- Building Permit from *County Building Division*
- Well/Septic from *County Health Department*
- Timber Land Conversion from *California Department of Forestry*
- Waste Discharge Permit from *Lahontan Regional Water Quality Control Board*
- Other _____

IV. SERVICES

1. Indicate how the following services will be provided for your project and the availability of service.

Electricity Southern California Edison

Underground Overhead (Show location of existing utility lines on Plot Plan)

Road/Access Proposed Access Road adjoining Lower Rock Creek Road

Water Supply Private Water

Sewage Disposal Private Septic System

Fire Protection Wheeler Crest Community Services District

School District Round Valley Joint Elementary/Bishop Union Joint High School District

2. If an extension of any of the above is necessary, indicate which service(s), the length of extension(s), and the infrastructure proposed _____

Electricity will be installed in road shoulders.

CERTIFICATION: I hereby certify that I have furnished in the attached exhibits the data and information required for this initial evaluation to the best of my ability, and that the information presented is true and correct to the best of my knowledge and belief. I understand that this information, together with additional information that I may need to provide, will be used by Mono County to prepare a Specific Plan in compliance with state law.

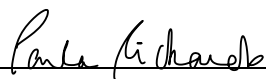
Signature  Date 2-26-2021

For _____

NOTE: Failure to provide any of the requested information will result in an incomplete application and thereby delay processing.

Camp ng Zone

026-330-002-000

[View or Print Value Notice](#)

Address	Unassigned
Community	Paradise Estates
Complex	
Land Use Designation	ER and SP
Zoning	NA
Transient Rental	To Be Determined
Voting Precinct	11 - Swall Meadows
Supervisor District	Dist #2: Rhonda Duggan
GIS Calculated Acres	55.3
Previous Assessment #	002633002000000
Latitude/Longitude	37.481607, -118.601274

Agr cu tura Zone

Man
Bu dng
Zone

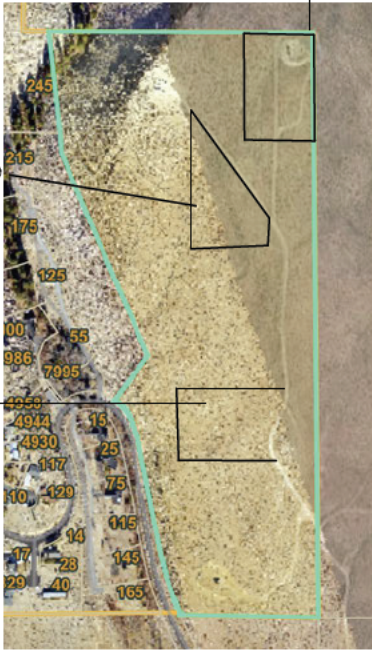



Lower We / Pump House



Cottonwood and Aspen Tress and native plantings, area that will receive the byproduct from Envirolet composting system

We House #1 Lower We / Pump House 30 x30
55 x40 canopy nc udes area to store workshop tra er

244 gpm
 3 phase
 40 hp

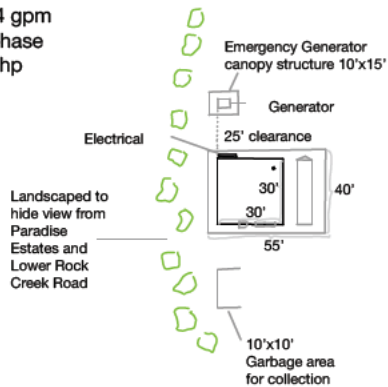

Man Bu d ng Zone

Phase 1

Primary Dwelling 50'x70' (Spartan Carousel 10'x50', Carport 30'x20', Garage/Wet room 40'x20')
 Enviolet Shed 10'x12'
 Detached Garage 60'x80'

Phase 2

Greenhouse 30'x60'
 Chicken Garden with Coop
 Utility Bldg 30'x60'
 Carport 25'x40'
 Canopy for Outdoor Living Space 30'x60'

Phase 3

Main Dwelling 140'x60'
 Enviolet shed 10'x20'

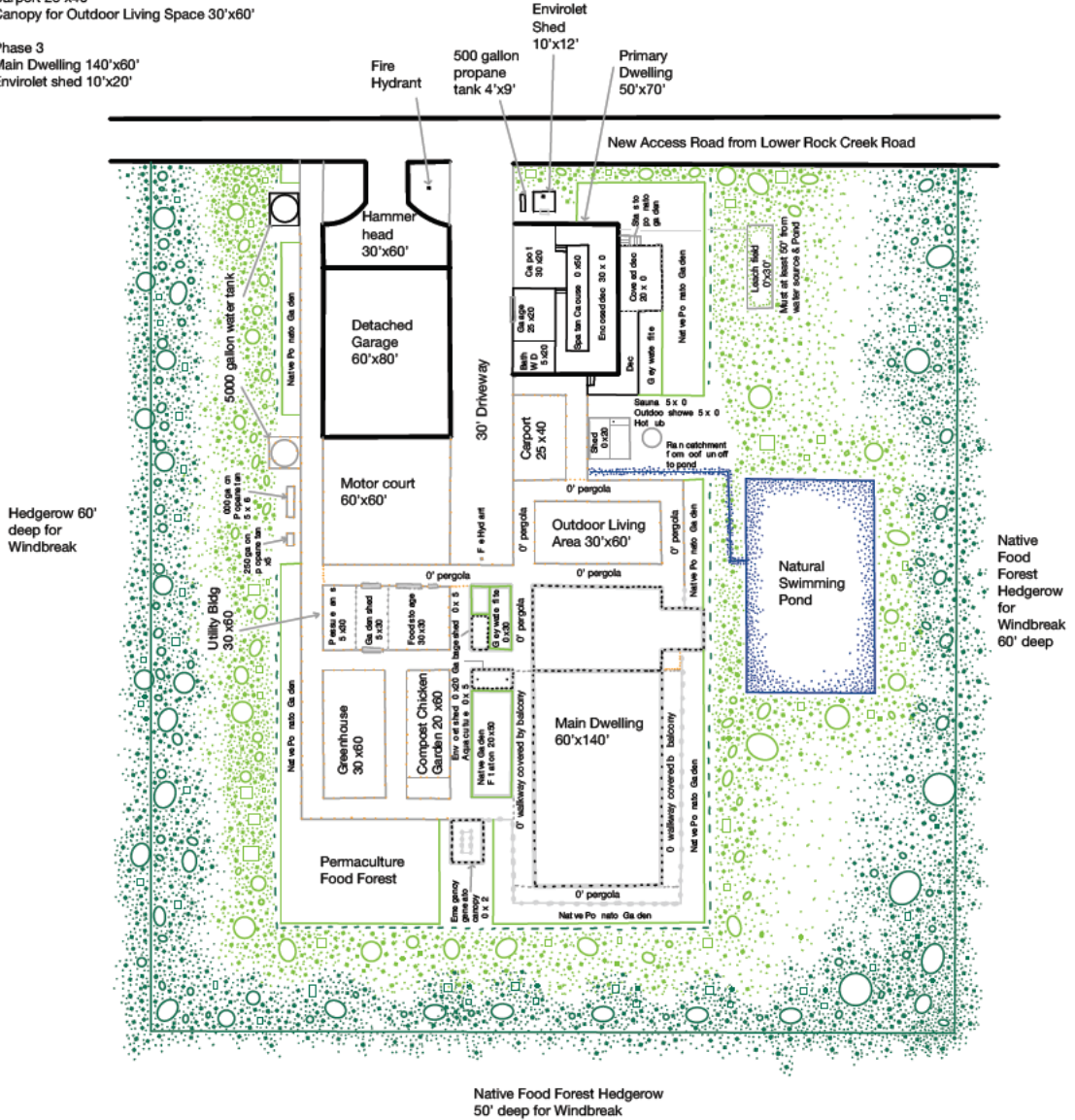

Agriculture Zone

approximate 5.4 acres which includes 1 acre of Orchard

Phase 2
 Greenhouse 40'x100' with Rainbow trout tank 20'x100'
 Greenhouse 40'x100' with Raised Minnow Pond 20'x100'
 Ponds and Bio retention cells system
 50,000 gallon water tank with Pump house 10'x20'
 Water system from Lower Well House
 Water system to Agricultural Zone, irrigation, channels and 5,000 gallon water tank

Barn 60'x100'
 Pig pen 30'x60'

Produce processing Bldg & Farm store 40'x100'
 Mushroom & Commercial Bldg 50'x100'
 Grain Feed Storage 30'x50'
 Tractor Farm Bay 30'x30'
 Chicken Compost Garden 40'x50'

Phase 3
 Pasture system
 Gardens

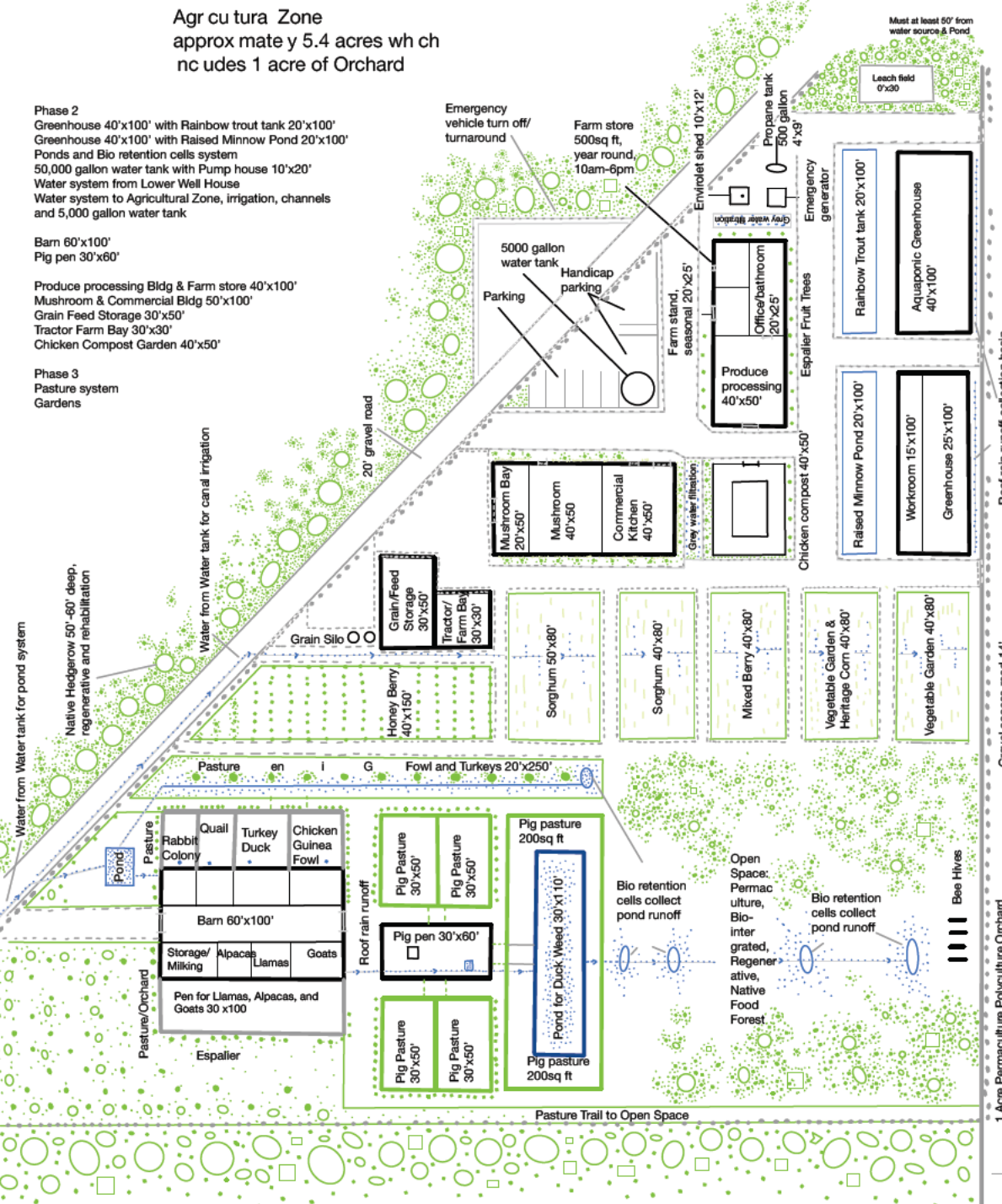

Must be at least 60' from water source & Pond

Leach field 0'x30'

Emergency vehicle turn off/turnaround

Farm store 500sq ft, year round, 10am-8pm

Propane tank 500 gallon

Emergency generator

Rainbow Trout tank 20'x100'

Aquaponic Greenhouse 40'x100'

5000 gallon water tank

Handicap parking

Parking

Farm stand, seasonal 20'x25'

Office/bathroom 20'x25'

Produce processing 40'x50'

Essential Fruit Trees

Raised Minnow Pond 20'x100'

Workroom 15'x100'

Greenhouse 25'x100'

Mushroom Bay 20'x50'

Mushroom 40'x50'

Commercial Kitchen 40'x50'

Grey water filtration

Chicken compost 40'x50'

Roof rain runoff collection basin

Water from Water tank for pond system

Native Hedgerow 50'-60' deep, regenerative and rehabilitation

Water from Water tank for canal irrigation

20' gravel road

Grain Feed Storage 30'x50'

Tractor/Farm Bay 30'x30'

Grain Silo

Honey Berry 40'x150'

Sorghum 50'x80'

Sorghum 40'x80'

Mixed Berry 40'x80'

Vegetable Garden & Heritage Corn 40'x80'

Vegetable Garden 40'x80'

Gravel access road 14'

Pasture for Fowl and Turkeys 20'x250'

Pasture for Rabbit Colony, Turkey Duck, Chicken Guinea Fowl

Barn 60'x100'

Storage/Milking, Alpacas, Llamas, Goats

Pen for Llamas, Alpacas, and Goats 30'x100'

Pasture/Orchard

Roof rain runoff

Pig Pasture 30'x50'

Pig Pasture 30'x50'

Pig pasture 200sq ft

Pig pen 30'x60'

Pond for Duck/Weed 30'x10'

Pig Pasture 30'x50'

Pig Pasture 30'x50'

Pig pasture 200sq ft

Bio retention cells collect pond runoff

Open Space: Permaculture, Bio-interactive, Regenerative, Native Food Forest

Bio retention cells collect pond runoff

Bee Hives

Pasture Trail to Open Space

1 Acre Permaculture Polyculture Orchard

Hedgerow 50'-60' deep, rehabilitation and regenerative

Camp ng Zone

Phase 1 and Phase 2

- Well House 10'x12'
- Carport 25'x30'
- Envirolet shed 10'x17'
- 4x Canopies 40'x60' with carport area 25'x25',
- Utility Shed 20'x25, deck and trailer
- 2x Envirolet shed 10'x12'
- 2x Solar System shed 20'x20'
- 2x 5,000 gallon water tanks
- Irrigation system
- Water system

Phase 3

- Pond system

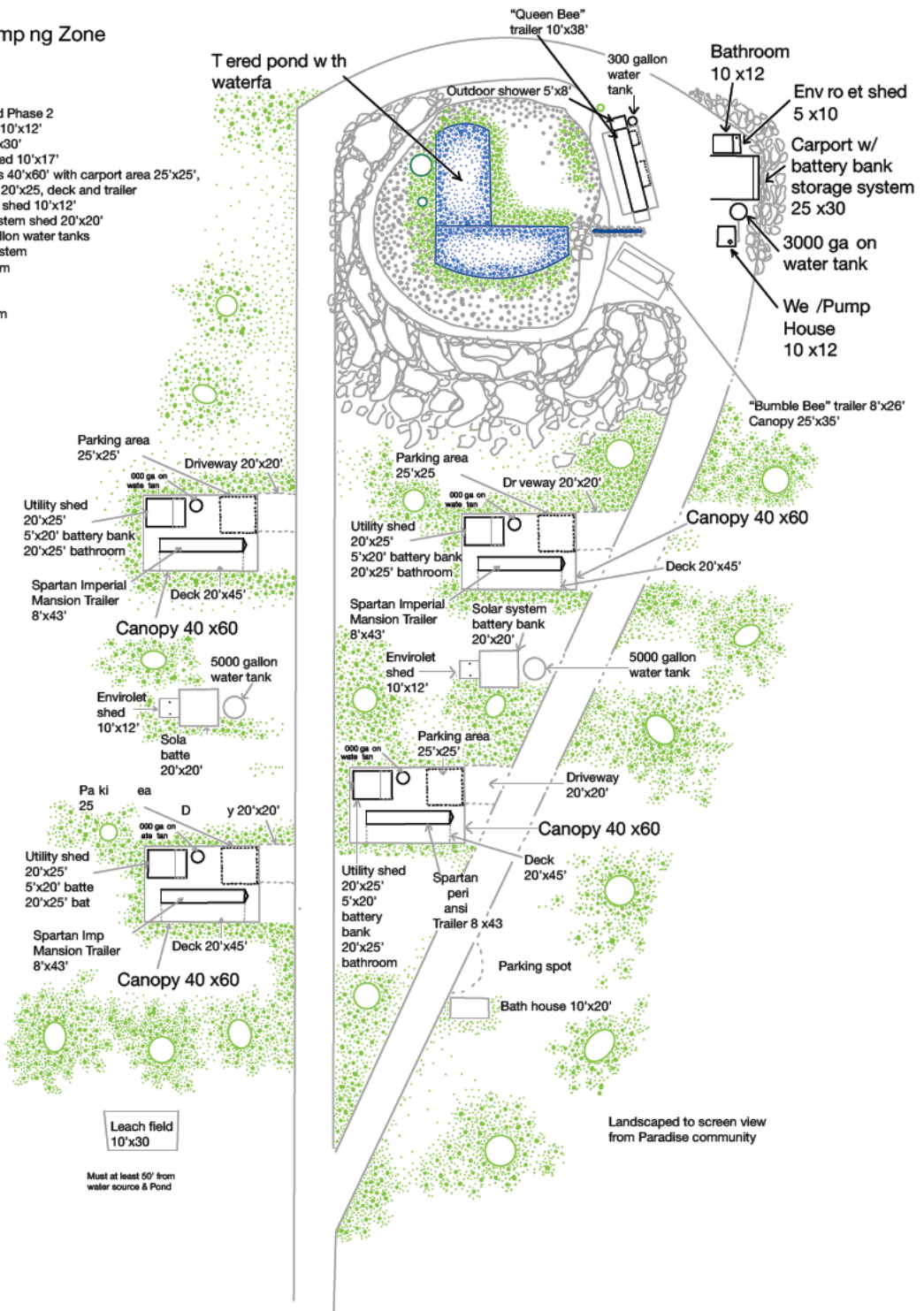

Tered pond w th waterfa

"Queen Bee" trailer 10'x38'

300 gallon water tank

Bathroom 10 x12

Env ro et shed 5 x10

Carport w/ battery bank storage system 25 x30

3000 ga on water tank

We /Pump House 10 x12

"Bumble Bee" trailer 8'x26' Canopy 25'x35'

Parking area 25'x25'

Driveway 20'x20'

Parking area 25'x25'

Dr veway 20'x20'

Canopy 40 x60

Utility shed 20'x25' 5'x20' battery bank 20'x25' bathroom

Spartan Imperial Mansion Trailer 8'x43'

Canopy 40 x60

5000 gallon water tank

Envirolet shed 10'x12'

Sola batte 20'x20'

Pa ki ea 25

D y 20'x20'

Utility shed 20'x25' 5'x20' batte 20'x25' bat

Spartan Imp Mansion Trailer 8'x43'

Canopy 40 x60

Utility shed 20'x25' 5'x20' battery bank 20'x25' bathroom

Spartan Imperial Mansion Trailer 8'x43'

Solar system battery bank 20'x20'

Envirolet shed 10'x12'

5000 gallon water tank

Parking area 25'x25'

Driveway 20'x20'

Canopy 40 x60

Utility shed 20'x25' 5'x20' battery bank 20'x25' bathroom

Spartan Imperial Mansion Trailer 8'x43'

Parking spot

Bath house 10'x20'

Leach field 10'x30

Must at least 50' from water source & Pond

Landscaped to screen view from Paradise community

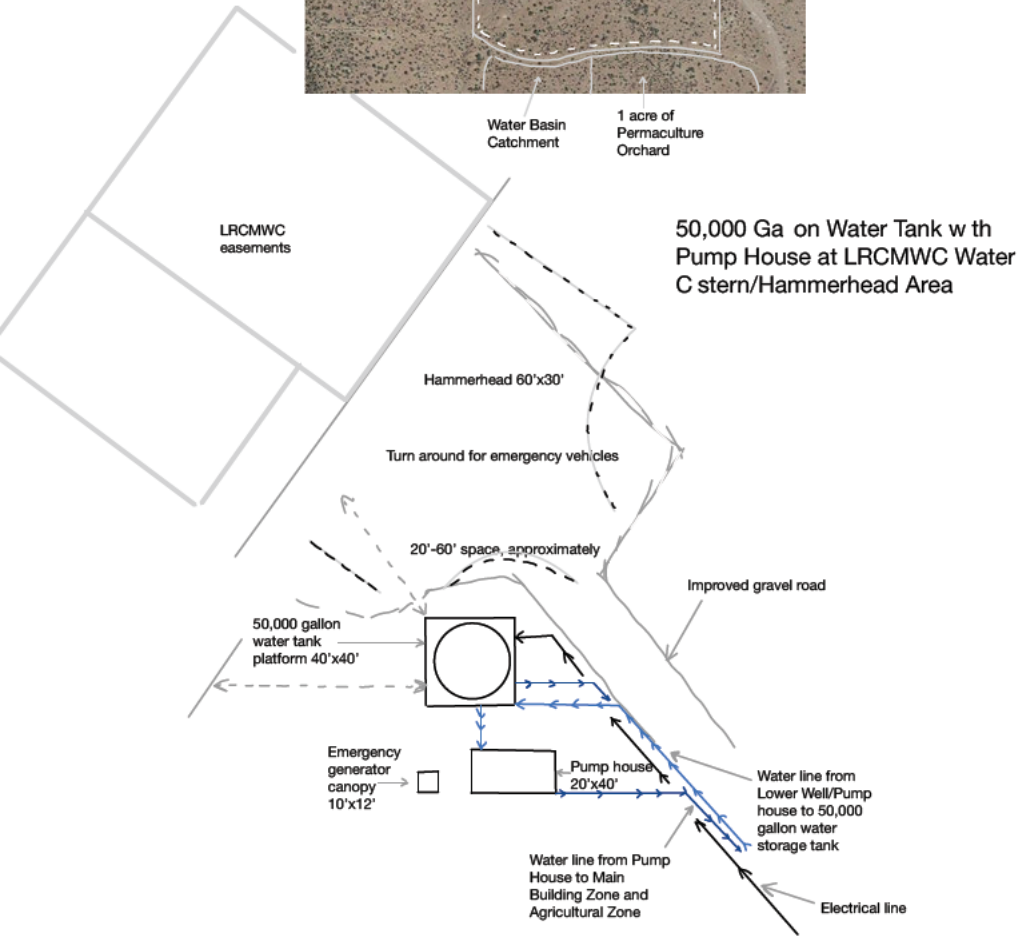
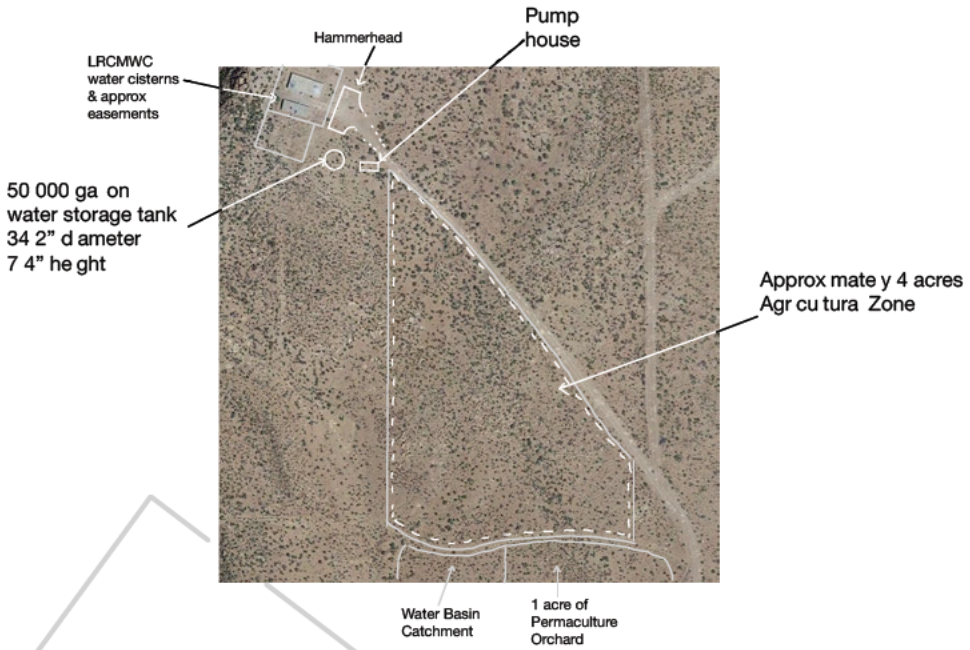

Addendum to the Amended Rock Creek Ranch Specific Plan

The Rock Creek Ranch project is located on a 54.64 acre parcel adjacent to the Paradise community in Southern Mono County. The project site, known as the "East Ridge", is a privately owned property located on unincorporated land. The site is currently undeveloped except for several graded, unpaved, roads, one well at the southwest corner and a second well at the northeast corner, as well as other structures to safeguard the well heads. The LRCMWC easements are occupied by 110,000 gallon potable water cisterns and distribution lines leading westward to existing homes in the Paradise community.

The purpose of the Rock Creek Ranch Specific Plan is to establish a formal link between implementing the policies of the Mono County General Plan and the Rock Creek Ranch development proposal. This addendum to the second amendment of the Rock Creek Specific Plan includes the following:

1. Reduces the number of lots from 10 lots to 1 lot.
2. Reduces impact from 10 driveways to only 1. Uses existing primitive roads as the base of the new paved road. The access from Lower Rock Creek Road is reduced which should reduce the disturbance to the neighborhood. Impact from the development is further reduced which improves the habitat for native plants and conforms to maintaining the Mule Deer migration corridor as it increases the private open space to over 40 acres.
3. Increases the single phase (development of the infrastructure of the parcel) to two phases which further reduces any harmful mitigating factors, each phase will be accessed to the standards by which development will proceed.
4. The addendum of the amended Specific Plan is in substantial conformance - the relationship of the amended Specific Plan to the General Plan of Mono County of distribution, location, and extent of land uses, including open spaces, remains the same.

The original Specific Plan details remain in effect such as a proposed Cell Tower site, colors, implementation and concerns for the neighborhood, etc.

Phase 1:

The parcel will be 1 Lot as per the site plan.

For the most part, the plan remains the same from the amended Specific Plan: All site improvements which include grading of roads, and the infrastructure improvements to develop on site water and drainage systems, and installation of other utility systems (power, communication, etc). This includes the building of the Lower Well house, the Upper Well House, the Pump House of the Agricultural Zone and the installation of a 50,000 gallon storage water tank located near the water cisterns of LRCMWC.

Main Building Zone

1. New Access point from Lower Rock Creek Rd. The electrical and communication lines will be installed underground on the side of the road.
2. Construction of road and driveway to Main Building site.
3. Building Lower Well/Pump House and installation of a 50,000 gallon water tank located between the Agricultural Zone and the water cisterns of Lower Rock Creek Mutual Water Co¹.
4. Driveway/road to Main Building site. For the most part, there will be an improvement to the existing road.
5. Primary Use Dwelling construction.

Agricultural Zone

1. Pump house for the 50,000 gallon water storage tank with Hybrid solar system.
2. Development of water infrastructure which includes: temporary and permanent irrigation lines, water tank, and water lines to water features (ponds and fish tanks).
3. Electrical and communication lines.

Camping Zone

1. Upper Well/Pump House adding an additional solar run well pump and new booster pump that will run off grid.
2. Carport metal building for solar system battery bank.
3. Water storage tanks, temporary and permanent irrigation lines, and water lines.
4. Development of site(s) that will be used for overnight stays by the owners during the construction and development of the property.

Phase 2:

During phase 2, the focus will be on further development of the Main Building Zone. This will include the majority, if not all, of the accessory buildings such as, the detached garage, home greenhouse, utility buildings, etc.

The development of the Agricultural Zone will begin with the greenhouses, support buildings, and planting of the orchard during phase 2, with an emphasis on building an integrated, bio-intense, permaculture design ecosystem.

Because the Camping Zone is off grid and mostly self contained, it could easily be completed at the beginning of the first phase. This is done so as to allow the owners to stay overnight on the property during construction and development of the project.

During the second phase, the hedgerows will be planted along with some parts of the native landscape plan. Hedgerows for windbreaks and screening are extensive and will take approximately 7 years to be established.

¹ Please note that all water, electrical, and communication lines will be installed along the new road.

Phase 3:

The Main Building Zone will be completed.

Ponds will be installed in all 3 Zones.

Trails will be laid out throughout the parcel with native landscaping.

Projected Timeline:

Phase 1:

1. New Access Road from Lower Rock Creek Road. Driveway and Road construction.
2. Electrical and communication lines
3. Construction of Lower Well/Pump house.
4. Water infrastructure with lines from Lower Well/Pump house to 50,000 gallon water storage tank.
5. Primary use dwelling.
6. Water infrastructure with water lines from storage tank to Main Building Zone and Agricultural Zone.
7. Construction of Upper Well, carport battery bank system and water infrastructure for Camping Zone. Establishment of trailer(s). Possible completion of this zone

Phase 2:

1. Accessory buildings in the Main Building Zone.
2. Development of the Agricultural Zone with buildings, hybrid solar system, water and electrical layout and some pastures/orchards.
3. Planting of hedgerows along with the temporary irrigation lines.
4. Envirolet sheds w/water tanks, shower sheds w/water tanks, waste system, pole barns, trailer(s) installed in the Camping Zone if not completed in the first phase.

Phase 3:

1. Completion of the Main Building Zone.
2. Trails and native landscaping.
3. Pond systems.

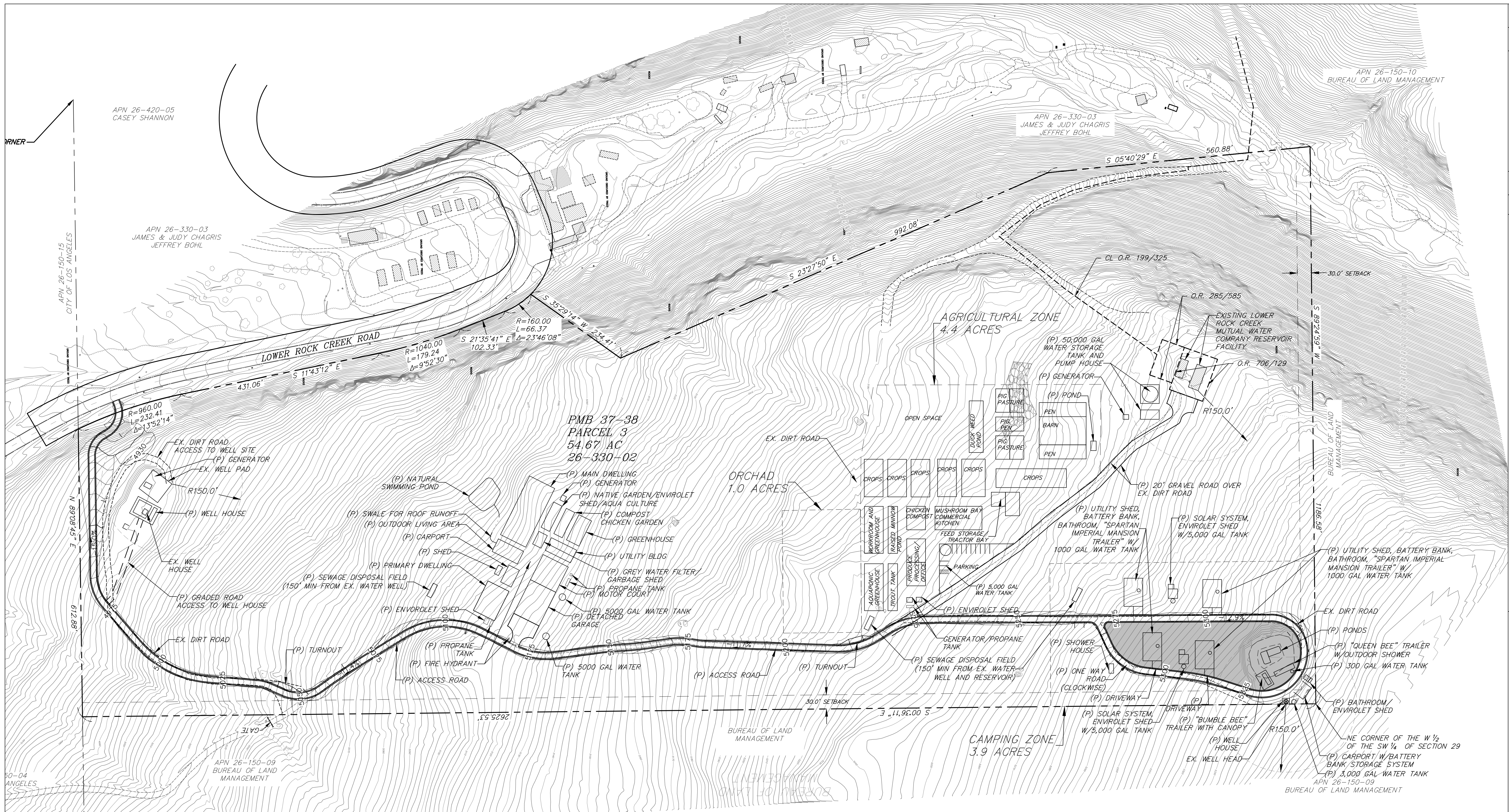

PMB 37-38
PARCEL 3
54.67 AC
26-330-02

AGRICULTURAL ZONE
4.4 ACRES

ORCHARD
1.0 ACRES

CAMPING ZONE
3.9 ACRES

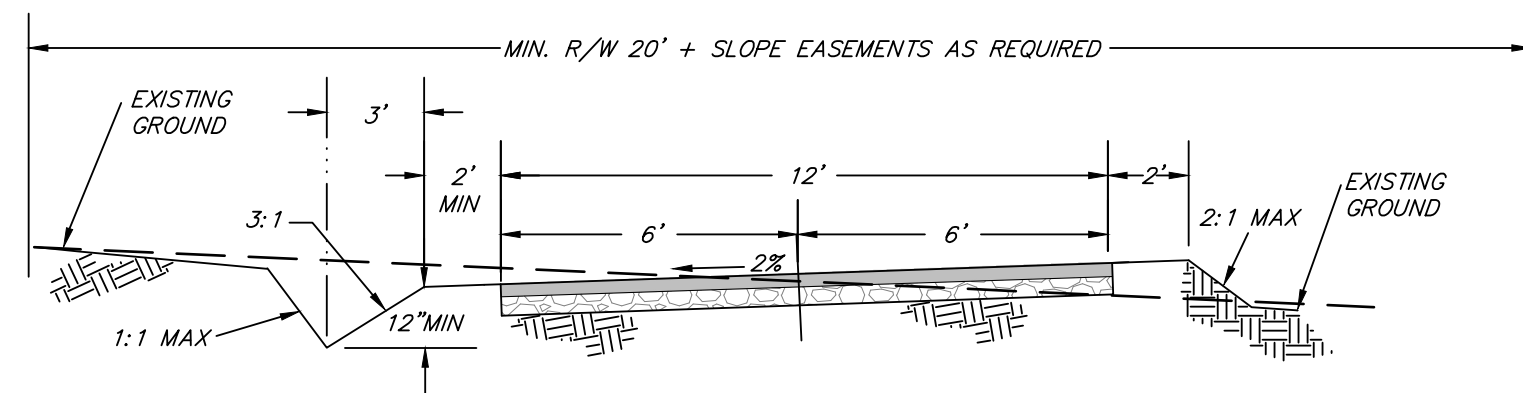

- NOTES:
1. PRIVATELY OWNED AND/OR MAINTAINED ROAD.
 2. SERVES 4 OR LESS RESIDENTIAL LOTS 1/4 ACRE OR GREATER IN AREA.
 3. MAXIMUM ROAD GRADE 15%.
 4. ROAD SECTION SHALL BE A MINIMUM OF 4" AC ON 6" CLASS 2 AGGREGATE BASE.
- TYPICAL DRIVE SECTION: CLASS 1 RESIDENTIAL
PLATE NO. 1 (WITH 6' TRAVEL LANES)
N.T.S.

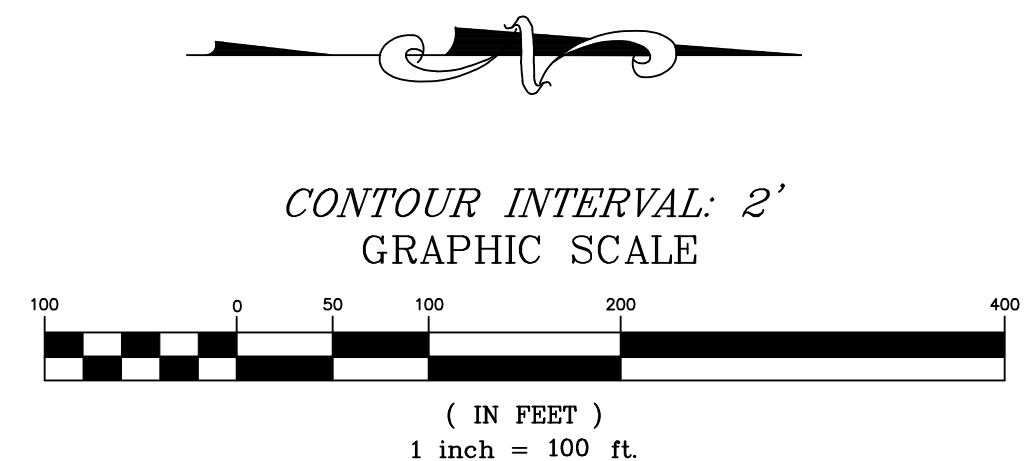

REVISIONS	BY	APPD
No.	Date	
1		
2		
3		
4		
5		

SITE CONTEXT MAP
ROCK CREEK RANCH
TIM & PAULA RICHARDS
COMMUNITY OF PARADISE, MONO COUNTY, CA

EASTERN SIERRA ENGINEERING
CIVIL ENGINEERING & CONSTRUCTION SERVICES
140 WHITNEY ALLEY
BISHOP, CA 93514
MAIN: (442) 228-5049
FAX: (775) 828-7221

Designed: DS
Drawn By: DS
Approved By: DG
Job No: 21327
Scale: AS SHOWN
Date: 6/17/21
SHEET No.
1 OF 1